

Dynamic Arm

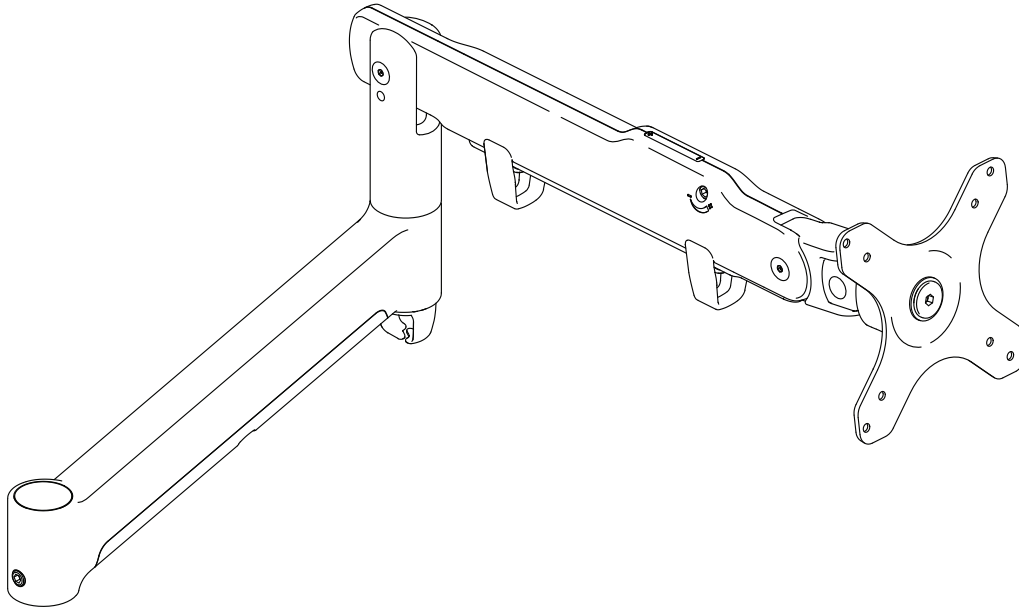

COMPONENT CHECKLIST

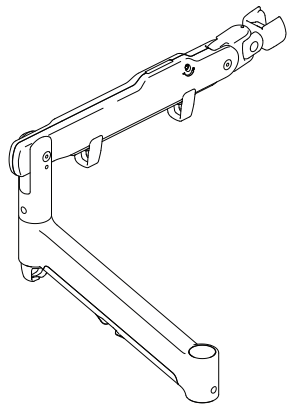

A
Dynamic
Monitor Arm
(x1)

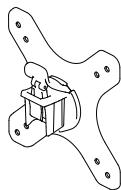

B
VESA
Head
(x1)



C
Screw
M4x25mm
(x4)



D
Screw
M4x16mm
(x4)



E
Screw
M4x12mm
(x4)



F
Spacer
(x4)



G
Security
Screw
(x1)



H
4mm
Hex Key
(x1)

Desk 

REQUIRED TOOLS

- Phillips Head Screwdriver

WEIGHT RANGE

Flat Monitors

0 - 9kg
(0 - 20lbs)

Curved Monitors

0 - 6kg
(0 - 13.5lbs)

Monitor weight should be within the weight range of all modular elements that make up the complete monitor mounting solution.

IMPORTANT INFORMATION

- ! Please ensure this product is installed as per these installation instructions.
- ! Do not remove/ throw away the plastic cap on channel clamp or base.
- ! This product is compatible with Atdec AWM Series products.
- ! The Dynamic Arm (AWM-AD) requires a Channel Clamp (AWM-LC, sold separately) for installation on an AWM Post.
- ! The Dynamic Arm (AWM-AD) requires a Desk Base (AWM-LB, sold separately) for installation directly onto an AWM fixing.
- ! The manufacturer accepts no responsibility for incorrect installation.
- ! Curved monitors, deep devices (such as all-in-one PCs), VESA mounted accessories (such as mini PC brackets and mounts), and offset VESA locations exert additional leverage that can exceed the capacity of the mount even though the monitor weight may be within the stated range. Please contact Atdec if you would like further information.

1. Set arm rotation to 180° (optional)

Note rotation is set to 360° by default.

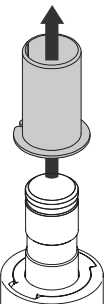
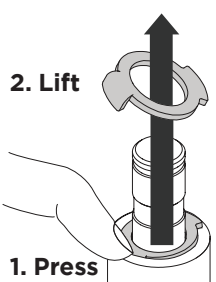
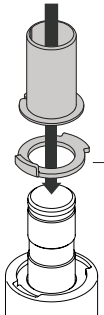
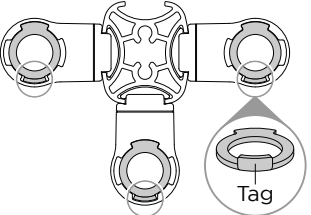
<p>1.1. On the Base or Channel Clamp (sold separately). Remove plastic sleeve.</p> 	<p>1.2. Remove rotation ring.</p> <p>2. Lift</p> <p>1. Press</p> 	<p>1.3. Place rotation ring in the desired position and replace plastic sleeve</p>  <div data-bbox="917 224 1045 537" style="border: 1px solid black; padding: 5px;"> <p>Default Position</p> <p>360°</p> <p>OR</p> <p>180°</p> <p>Flipped Position</p> </div>	<p>NOTE: When setting channel clamp rotation, orientate the ring depending on what post channel the arm will be attached to. The tag on the ring should always face towards the user.</p> 
---	---	---	--

2. Fit arm onto Base or Channel Clamp (sold separately)

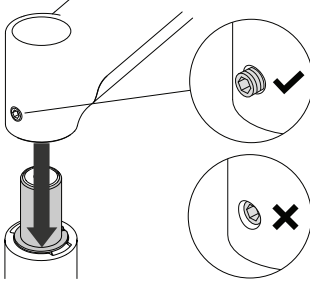
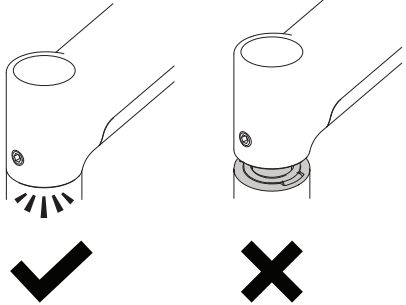
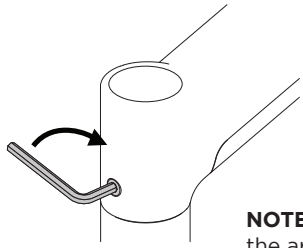
<p>2.1. Push arm onto shaft.</p> 	<p>2.2. Ensure arm is fully pushed onto shaft.</p> 	<p>2.3. Tighten joint screw.</p>  <p>NOTE: Check the arm rotation is smooth after tightening.</p>
--	---	--

3. Attach VESA head to monitor

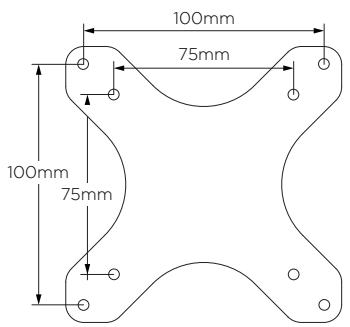
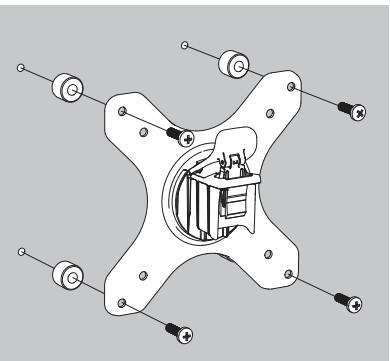
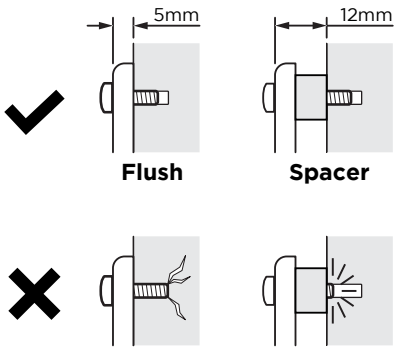
<p>3.1. VESA mounting compatibility</p>  <p>NOTE: For other sizes, use a suitable adaptor plate (sold separately).</p>	<p>3.2. Attach VESA head onto monitor with provided screws.</p>  <p>NOTE: Spacers may be required for curved, recessed or uneven monitor surfaces.</p>	<p>3.3. Be sure to use correct screw length</p>  <p>Flush Spacer</p> <p>Too long Too short</p>
--	---	--

4. Mount monitor on arm

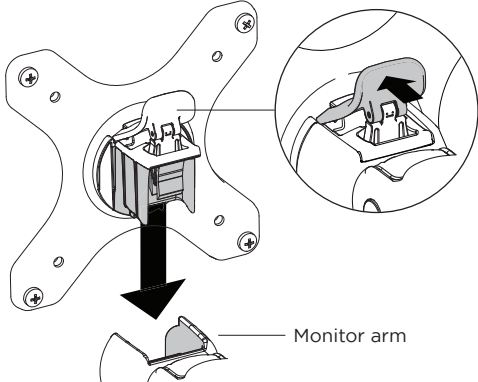
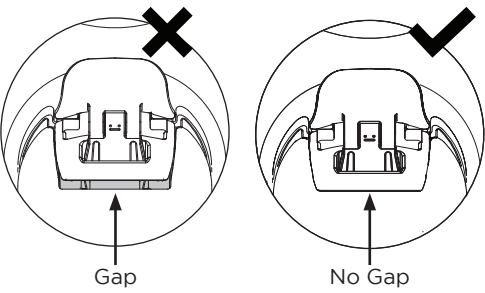
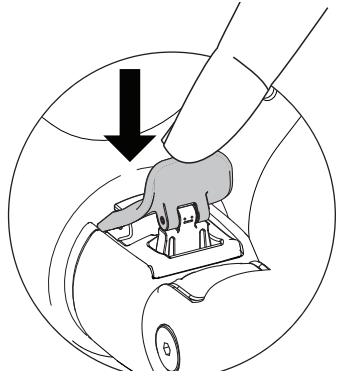
<p>4.1. Insert VESA head into the monitor arm</p>  <p>Monitor arm</p>	<p>4.2. Ensure that the VESA head sits flush within the monitor arm. There should be no gap.</p>  <p>Gap No Gap</p>	<p>4.3. Push the lever down to secure it to the arm assembly</p> 
--	--	---

5. Adjust tilt tension & install security screw

5.1. Use the allen key to adjust the tilt tension until the monitor holds in a vertical position at the end of the arm.

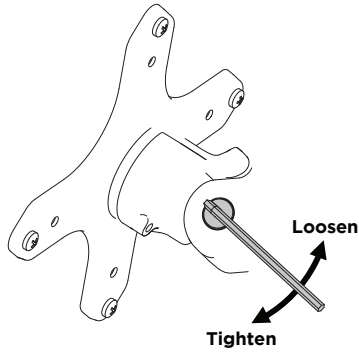

NOTE:
Support monitor while adjusting.

5.2. (OPTIONAL) Tilt the head upwards to install the optional security screw.

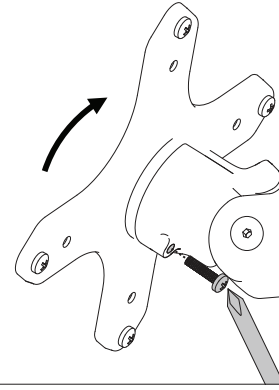

6. Adjust arm tension

6.1. To accurately set the tension of the arm, position the monitor at 90 degrees

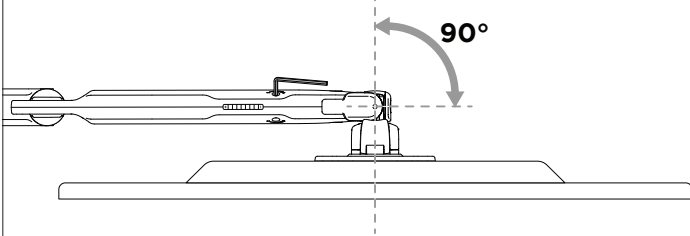

6.2. Use the allen key to adjust the arm tension to the weight of the monitor. Follow steps **6.3** to **6.5** to set the tension.

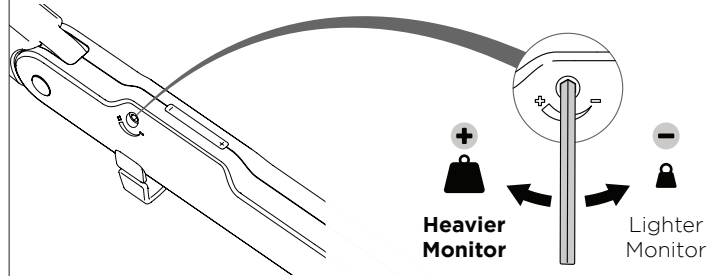

6.3. If the monitor sags or falls down, increase the arm tension by rotating the screw clockwise.

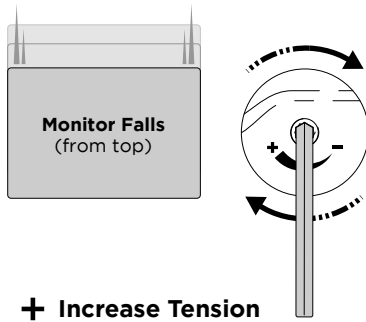

6.4. If the monitor springs upwards from the bottom position, decrease the arm tension by rotating the screw anti-clockwise.

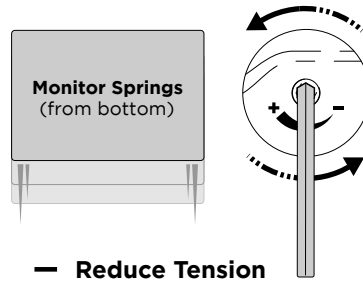

6.5. If the monitor floats or hovers in all positions the arm tension is balanced and does not require further adjustment.

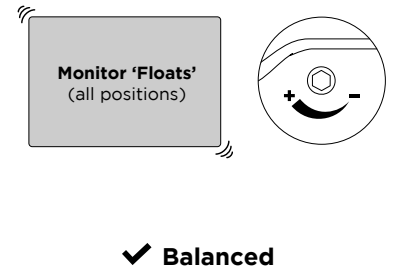

7. Tension gauge

7.1. When installing multiple monitors of a similar weight, use the tension gauge to make installation faster.

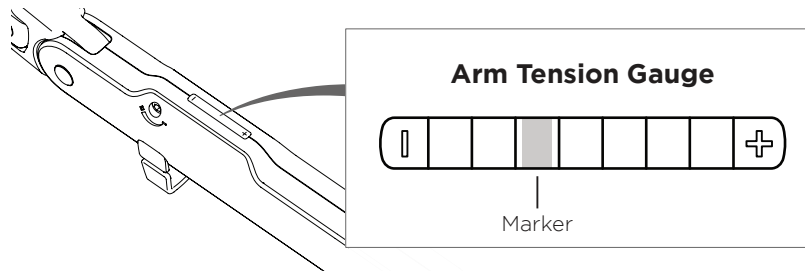

1. Set up one monitor and record the position of the marker on the gauge.
2. When installing subsequent monitors, pre-tension the arm to the recorded amount, then fine-tune the tension by following steps **6.3** to **6.5**.

8. Cable management

8.1. Plug cables into the monitor and route the cables down the arm using the cable hooks and clips.

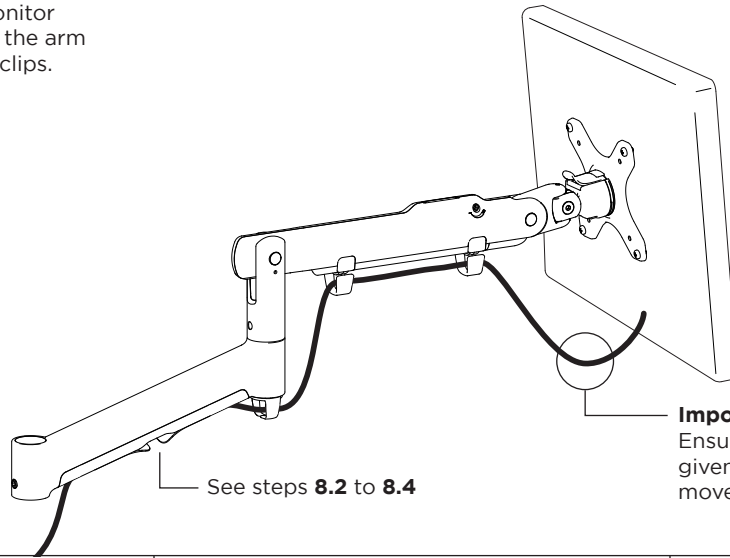

Important!

Ensure enough cable slack is given in this area to allow for movement of the monitor.

8.2. Wedge cable into the central gap and slide it down the arm.

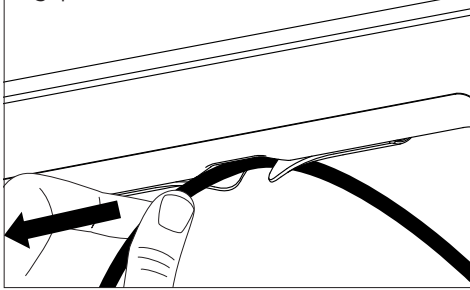

8.3. The cable should slip into the arm cavity.

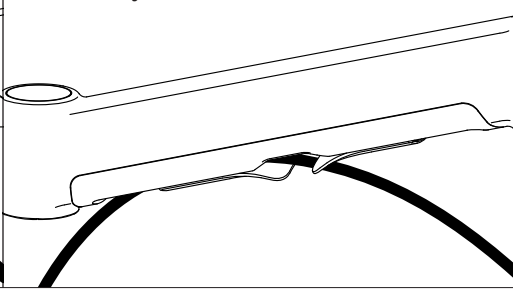

8.4. Slide the remaining loose cable from the central gap up the arm.

