

Component Checklist

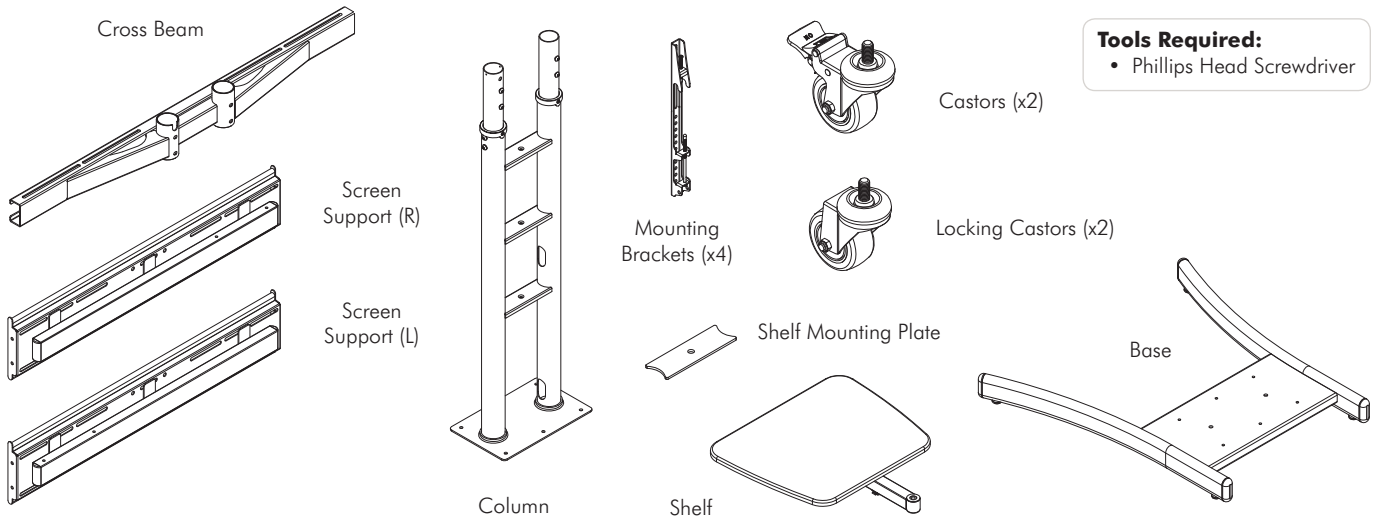

Tools Required:

- Phillips Head Screwdriver

HARDWARE

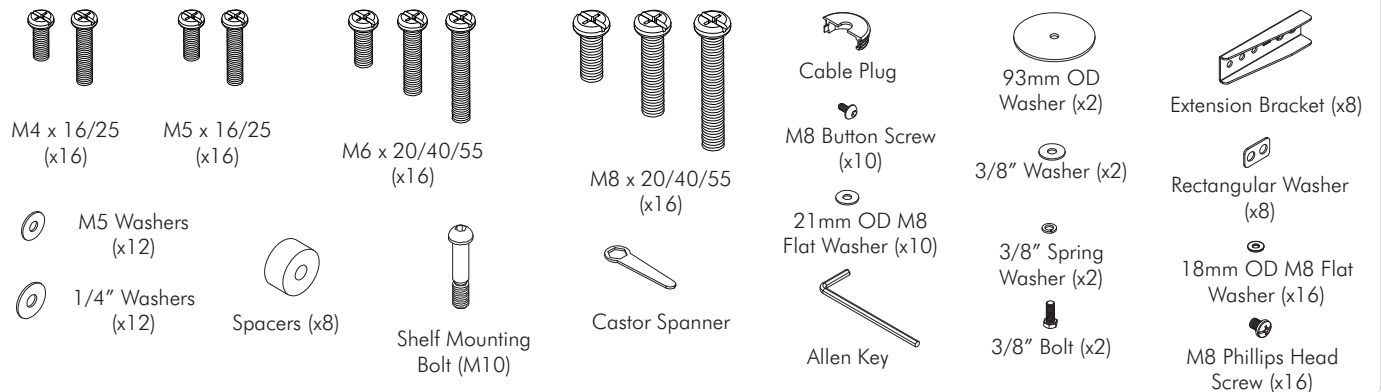

IMPORTANT INFORMATION:

- ! **IMPORTANT - Install TV Cart as per installation instruction.**
- ! This product supports a maximum load of 50kg (110lbs.)/Monitor.
- ! This product supports VESA Mounting Hole Configurations: From 200mm to 900mm wide and from 200mm to 400mm high (600mm high with extensions).
- ! The manufacturer accepts no responsibility for incorrect installation.

Step 1. Check Components

Check you have received against the component checklist and hardware above.

Step 2. Assemble Base

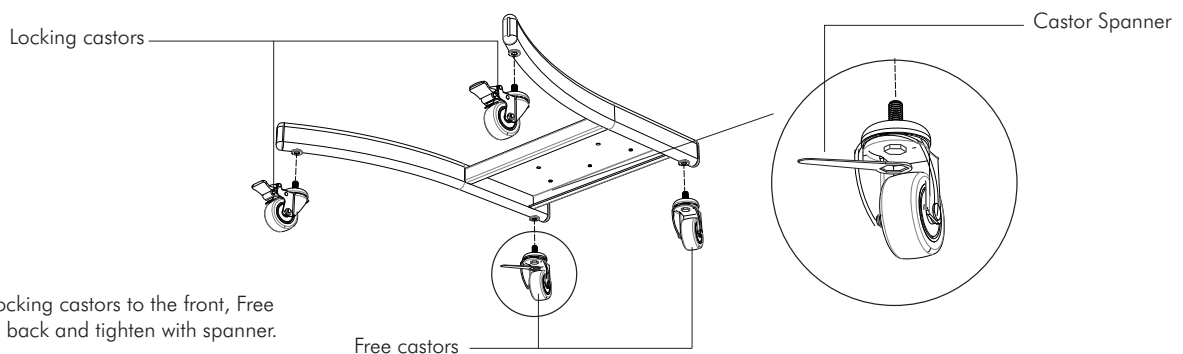

2.1 Mount Locking castors to the front, Free castors to the back and tighten with spanner.

Step 3. Mount Column to Base

3.1 Ensure column holes face the rear of the base.

3.2 Line holes up and secure column to base.

M8 Button Screw
21mm OD M8 Flat Washer
Holes

3.3 Secure column from beneath.

93mm OD Washer
3/8" Washer
3/8" Spring Washer
3/8" Bolt
Spanner

Step 4. Adjust Height

4.1 You can adjust the height by moving the tubes up or down before fastening them.

M8 Button Screw
Allen Key
M8 Curved Washer

Step 5. Mount Cross Beam

Note: Notch facing upwards

5.1 Mount cross beam onto column and fasten with screws.

M8 Button Screw
Allen Key

Step 6. Mount Screen Support

Tab facing upwards
Holes

6.1 Slide screen support into cross bar ensuring holes face the centre.

Max Extension: 1310mm

6.2 Fasten screen support to the cross beam and repeat for the other side.

21mm OD M8 Flat Washer
M8 Button Screw

Step 7. Attach Mounting brackets

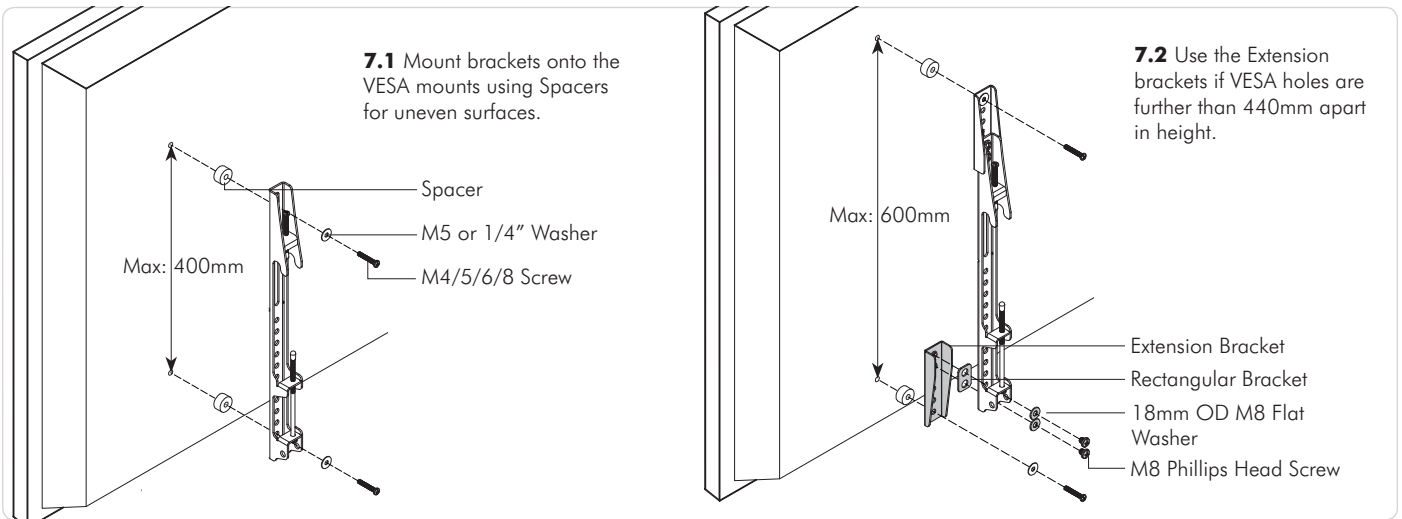

Step 8. Mount Screen

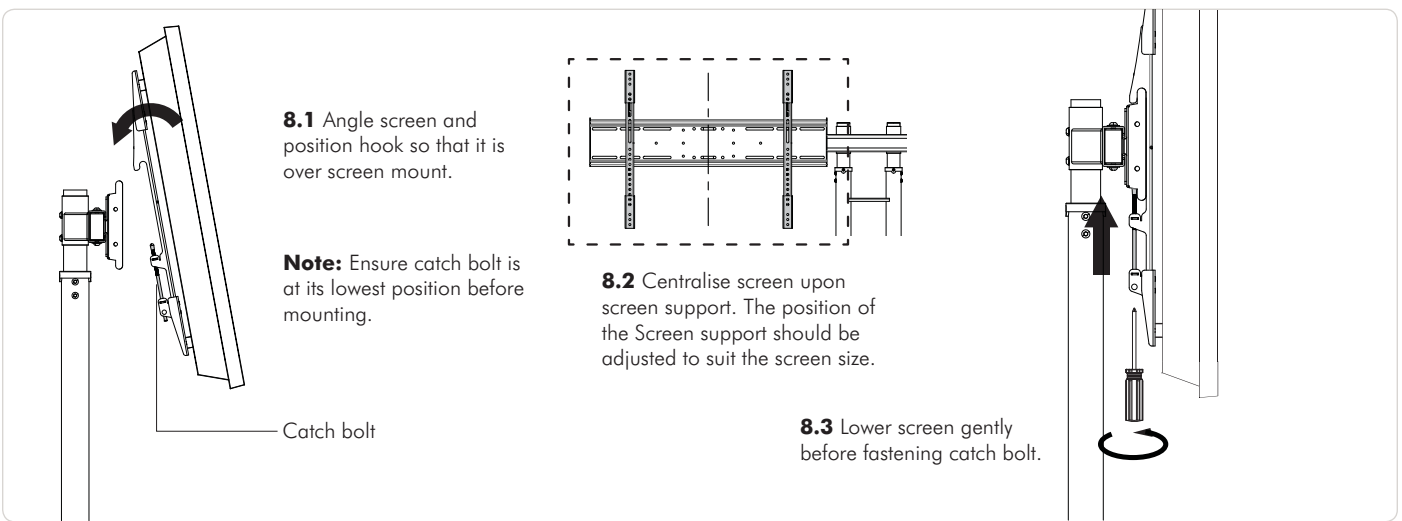

Step 9. Cable Management

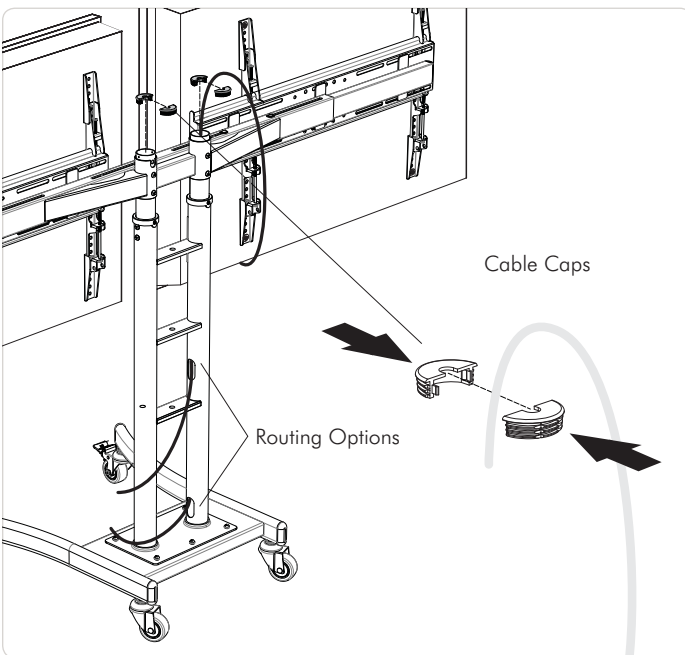

Step 10. Attach Shelf

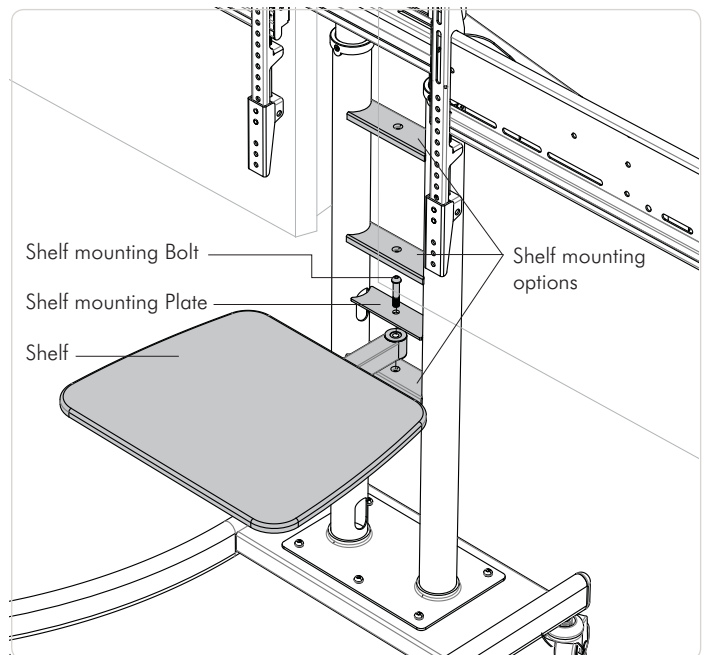

Installation Complete